

1: Apply glue to the holes

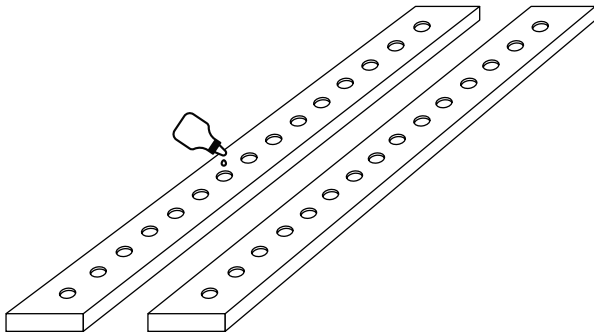

2: Using a hammer, drive the rods into one of two boards

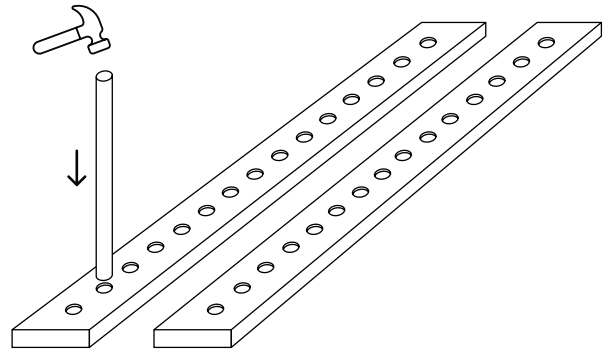

**3: We break the ladder together.
We recommend using a spacer
to avoid damaging the ladder**

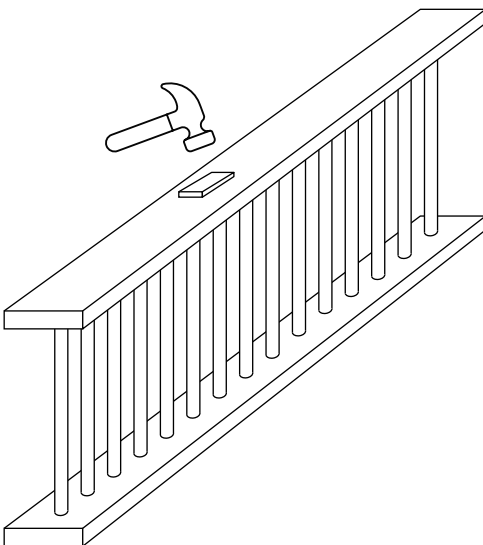

**4: We twist the ladder at the
points marked on the boards
using torx screws**

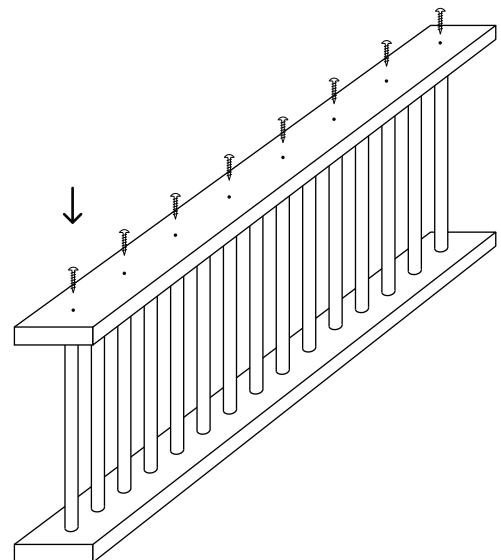

The remaining 4 dowels and screws are used to mount the ladder to the wall.
Any steps of this manual where hammer is required, we highly recommended to use spacer
(wood, plastic, hard rubber etc.) to balance the force and prevent destroying a gantla materials.

5: The ladder should be attached to the wall using the flat bars provided and screws at four marked points. The longer edge of the flat bar we attach to the ladder, while the shorter, using a dowel to the wall. The ladder should stand upright and lean against the wall.

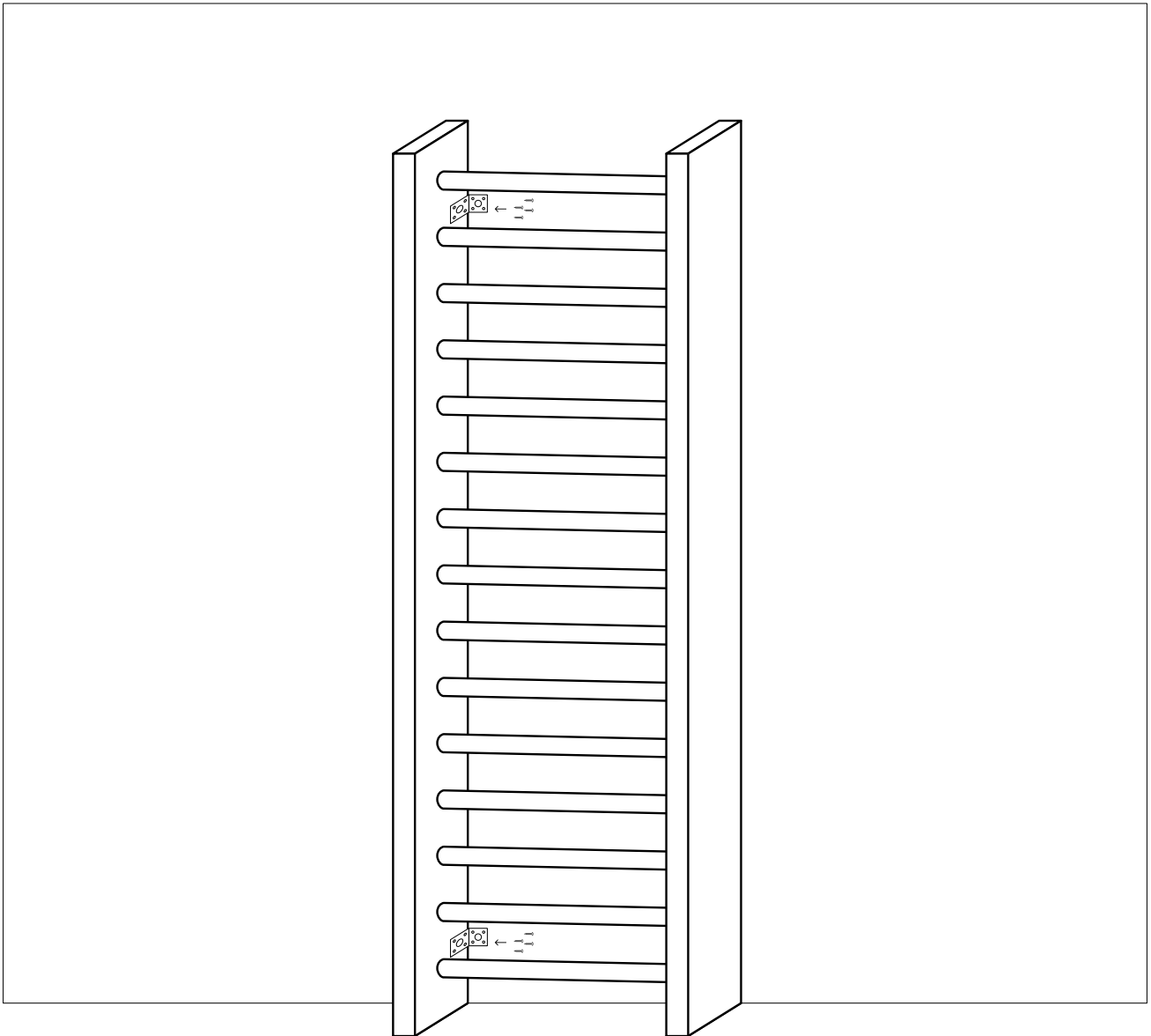

CAUTION!: Make strong and stable mounting